

**City of Negaunee  
PO Box 70  
319 W. Case Street  
Negaunee, MI 49866  
906 475-9991**

### **INVITATION FOR BIDS**

Sealed bids will be received by the City of Negaunee located at 319 W. Case Street, Negaunee, Michigan, 49866 until 1:00PM (EST) April 24, 2023 for Custom Bench/Planters for the Negaunee Downtown Enhancement Project.

Bid shall be submitted and addressed to the Negaunee City Clerk, City of Negaunee, PO Box 70, 319 W. Case Street, Negaunee, MI 49866. Envelope shall be sealed and clearly marked "Bid for Custom Bench/Planters – Negaunee Downtown Enhancement Project." Bids must be received before the above date and time. No fax or email bids will be accepted.

Bids will be opened on April 24, 2023 at 1:00PM (EST) at 319 W. Case Street (City Hall), second floor conference room.

The City reserves the right to accept any or all bids or accept any part of a bid. Each of the items may be purchased individually or as a lump sum bid.

# Custom Planters and Benches

## Item 1: Quantity 4

Raised planting bed with 18" deep bench StreetLife Solid Edge System or equivalent.  
 Side wings Length measuring 118", 110 degree angles on each side wing, tapering from 19" height to 0".  
 Material: Weathering steel, class A, 4 mm Bench material: solid composite material.

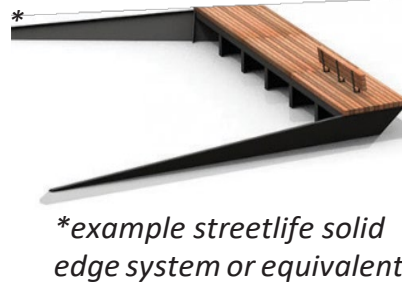
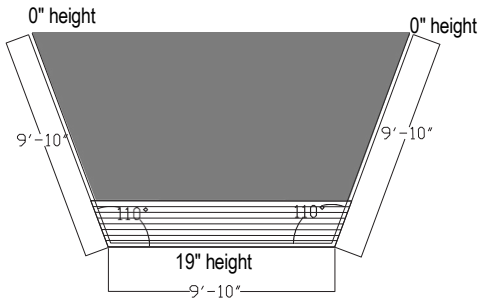

## Item 2: Quantity 1

Raised planting bed with 18" deep bench. StreetLife Solid Edge System or equivalent.  
 Side wings Length measuring 118" and 236,"110 degree angles on each side wing, tapering from 19" height to 0". Long edge on right hand side.  
 Material: Weathering steel, class A, 4 mm Bench material: solid composite material.

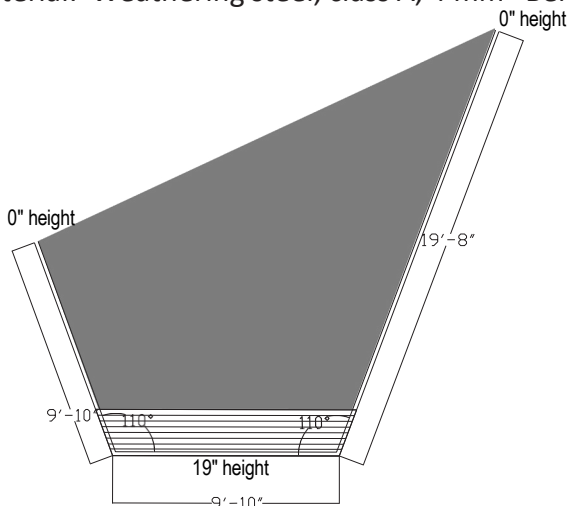

## Item 3: Quantity 1

Raised planting bed with 18" deep bench. StreetLife Solid Edge System or equivalent.  
 Side wings Length measuring 118" (left hand side) and 236" (right hand side) 110 degree angles on each side wing, tapering from 19" height to 0". Long edge on left hand side.  
 Material: Weathering steel, class A, 4 mm Bench material: solid composite material.

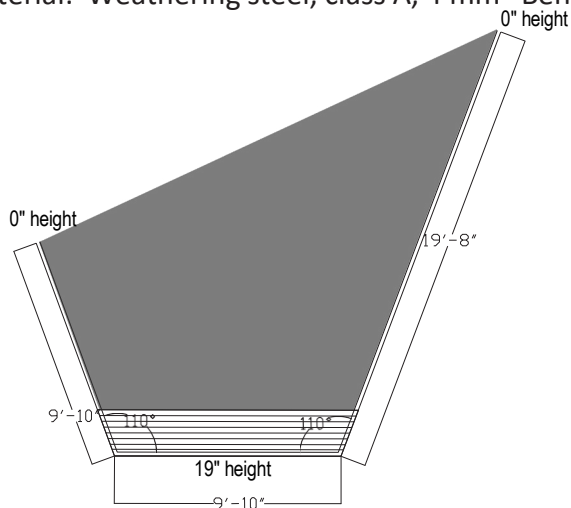

**Item 4: Quantity 1**

Raised planting bed with 18" deep bench. StreetLife Solid Edge System or equivalent.

Side wings Length measuring 236" and 236,"110 degree angles on each side wing, tapering from 19" height to 0".

Material: Weathering steel, class A, 4 mm Bench material: solid composite material.

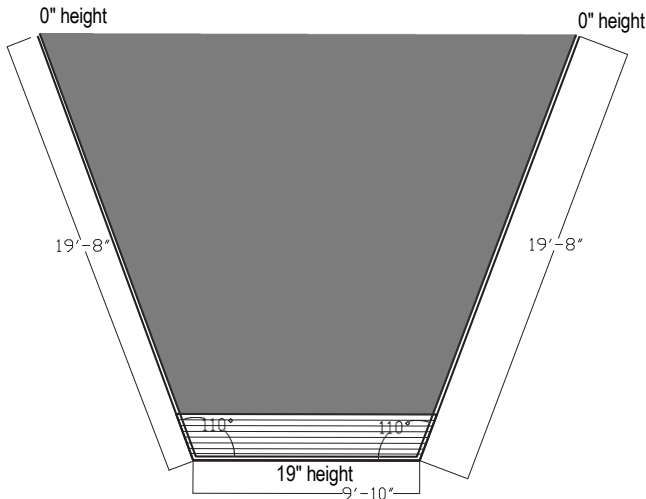

**Item 5: Quantity 3**

Weathering Steel Planter Bench with seat on one side. StreetLife Rough and Ready Big Green or Equivalent.

Size: (W x D x H) Planting tub: 59" x 59" x 16", Tub and Seat: 59" x 63" x 18"

Materials: Frame & planter tub weathering steel, class A, 4mm Bench Material: Solid composite

Imbedded Mounted Seat: 4" overhang, Slats 2.8" x 16" x 5.9"

Integrated USB charging port, closed bottom designed to accommodate placement and removal by forklift with holes for drainage.

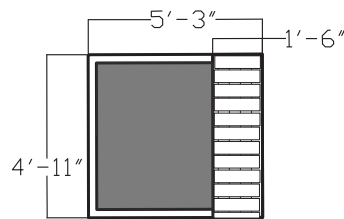

**Item 6: Quantity 7**

Weathering Steel Planter Bench, StreetLife Rough and Ready Big Green or Equivalent.

98" x 39" x 18" with seat on long side.

Tub and Seat: 98" x 39" x 18"

Materials: Frame & planter box: weathering steel, class A, 4mm Bench Material: Solid composite

Imbedded Mounted Seat: 4" overhang, Slats 2.8" x 16" x 5.9"

Integrated USB charging port (or provision for USB charging port installation) closed bottom with provisions for forklift and holes for drainage.

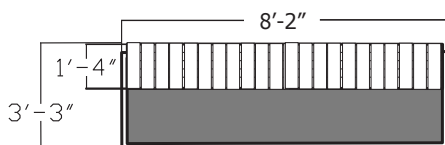

Item 7: Quantity 1

Oval Raised Planter Bench, StreetLife Rough and Ready Oval Tree Isle or equivalent.

16' diameter by 36' diameter, 18" height.

Imbedded Mounted Seat: 13' length, 4" overhang, Slats 2.8" x 16" x 5.9"

Material: Weathering steel, class A, 4 mm Bench material: solid composite material.

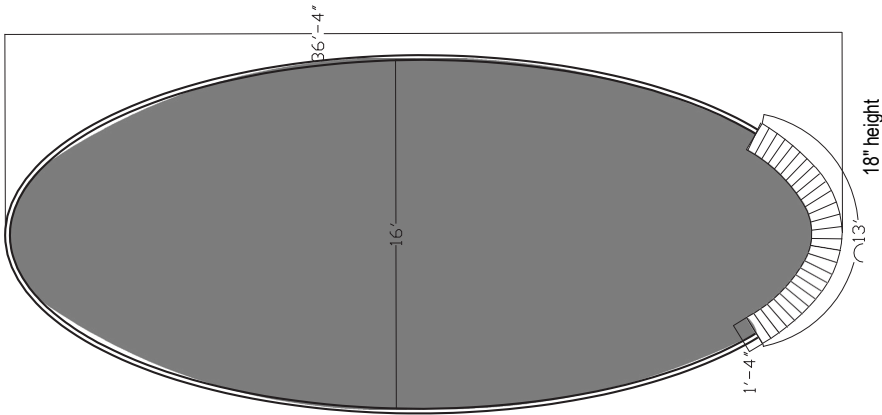

\*example streetlife R&R Oval Tree Isle or Equivalent

Item 8: Quantity 2

Weathering Steel Planter combination with corner wall benches. StreetLife Hug-a-Tub with corner wall benches or Equivalent.

Size: (W x D x H) Planting Tub 79" x 79" x 35", Corner wrap Rough and Ready benches; 20" wide with backrest

Materials: Frame & planter box: weathering steel, class A, 4mm Bench Material: Solid composite

Closed bottom designed to accommodate placement and removal by forklift with holes for drainage.

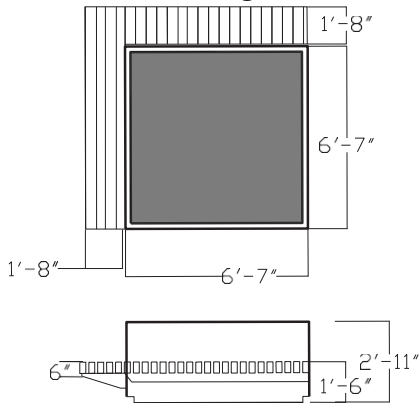

\*example streetlife hug-a-tub or equivalent

Item 9: Quantity 1

Weathering Steel Planter Bench with seat on three sides and Trellis. StreetLife Rough and Ready Mobile Green Isle or Equivalent.

Size: (W x D x H) Planting tub: 118" x 59" x 19", Seat: 18" deep, Trellis: 6' wide x 8' high

Materials: Trellis, Frame & planter tub weathering steel, class A, 4mm

Imbedded Mounted Seat: Solid composite, 4" overhang, Slats 2.8" x 18" x 5.9"

Closed bottom designed to accommodate placement and removal by forklift with holes for drainage.

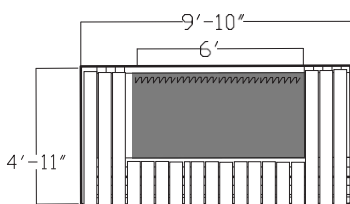

\*example streetlife green screen or equivalent; manufacturer to provide shop drawing of trellis and attachment details



\*example streetlife mobile green isle or equivalent (does not show weathering steel and composite slats)

Item 10: Quantity 2

Weathering Steel Planter Benches on two short sides, StreetLife Rough and Ready Mobile Green Isle or Equivalent.

Size: (W x D x H) Planting Tub with Seat: 118" x 59" x 19" with seat on short sides.

Materials: Frame & planter box: weathering steel, class A, 4mm Bench Material: Solid composite

Imbedded Mounted Seat: 4" overhang, Slats 2.8" x 16" x 5.9"

Integrated USB charging port (or provision for USB charging port installation) closed bottom with provisions for forklift and holes for drainage.

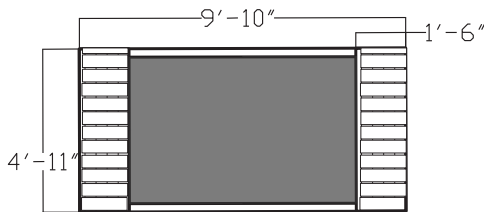

*\*example streetlife mobile green isle or equivalent (does not show weathering steel and short composite slats)*

Item 11: Quantity 1

Weathering Steel Planter Bench with Trellis, StreetLife Rough and Ready Big Green or Equivalent.

98" x 39" x 18" with seat on long side and trellis on other long side.

Tub and Seat: 98" x 39" x 18", Trellis: 7'5" wide x 8' high

Materials: Trellis, Frame & planter box: weathering steel, class A, 4mm Bench Material: Solid composite

Imbedded Mounted Seat: 4" overhang, Slats 2.8" x 16" x 5.9"

Integrated USB charging port (or provision for USB charging port installation) closed bottom with provisions for forklift and holes for drainage.

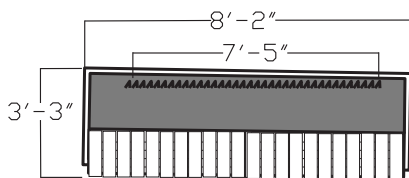

*\*example streetlife green screen or equivalent; manufacturer to provide shop drawing of trellis and attachment details*

Dimensions are approximate. Slight deviation to allow for standard measurements allowable. Final dimensions to be approved by owner prior to manufacture.

All items delivered assembled and ready to install.

Shipping (priced by shipping source)

Shipping by source

Delivered to:600 Cherry Street, Negaunee, Michigan 49866

**BID FORM**

Vendor \_\_\_\_\_

Address \_\_\_\_\_

City of Negaunee - Custom Planters and Benches				
Item Number + Description	Quantity	Unit	Unit Price	Total Price
Item 1: Edge System: 118x118" wings	4	Each		
Item 2: Edge System: 118x236" wings	1	Each		
Item 3: Edge System: 236x118" wings	1	Each		
Item 4: Edge System: 236x236" wings	1	Each		
Item 5: Bench/Planter: 59x63x18"	3	Each		
Item 6: Bench/Planter: 98x39x18"	7	Each		
Item 7: Oval Planter with Bench: 16'x36'	1	Each		
Item 8: Corner Bench with Back/Planter: 79x79x35"	2	Each		
Item 9: Wrap Around Bench/Planter with Trellis: 118x59x19"	1	Each		
Item 10: Benches on Ends with Planter: 118x59x19"	2	Each		
Item 11: Bench/Planter with Trellis: 98x39x18"	1	Each		
Item 12: Shipping Estimate				

Alternates - Custom Planters and Benches				
Item Number + Description	Quantity	Unit	Additive (or Deductive) Amount	Total Price
Item 1: With wood bench slats*	4	Each		
Item 2: With wood bench slats*	1	Each		
Item 3: With wood bench slats*	1	Each		
Item 4: With wood bench slats*	1	Each		
Item 5: With wood bench slats*	3	Each		
Item 6: With wood bench slats*	7	Each		
Item 7: With wood bench slats*	1	Each		
Item 8: With wood bench slats*	2	Each		
Item 9: With wood bench slats*	1	Each		
Item 10: With wood bench slats*	2	Each		
Item 11: With wood bench slats*	1	Each		

\*Submittal required noting wood species and treatment to be approved by owner's representative prior to manufacture.